



High Pressure Equipment

Taper Seal Valves, Fittings and Tubing **10,000 and 15,000 psi service**

High Pressure Equipment Company has developed the Taper Seal line of products to assure safe and easy plumbing through 15,000 psi. These needle valves, fittings, line filters, check valves, safety heads, rupture discs and tubing are engineered and manufactured to the highest standards of repeatable quality. The reliable performance of these products has made HiP one of the world's leading suppliers of elevated pressure components.

The Taper Seal is a compression type tube connection that is extremely easy to use and re-make. The sleeve clamps onto tubing much like a machine collet for a safe and reliable connection. Taper Seal valves are available in $\frac{1}{16}$ ", $\frac{1}{8}$ ", $\frac{1}{4}$ ", and $\frac{3}{8}$ " O.D. tubing sizes and five patterns to satisfy widely varied requirements. A line of fittings is available to facilitate adapting to Medium Pressure or High Pressure systems.



Index

Page

| | |
|--------------------------|----------|
| Valves | 2.2-2.3 |
| Fittings | 2.4 |
| Line Filters | 2.5 |
| Check Valves | 2.5 |
| Safety Heads | 2.6 |
| Rupture Discs | 2.7 |
| Tubing | 2.7 |
| Connection Details | 2.A |
| | Appendix |



High Pressure Equipment

Taper Seal Needle Valves 10,000 and 15,000 psi service

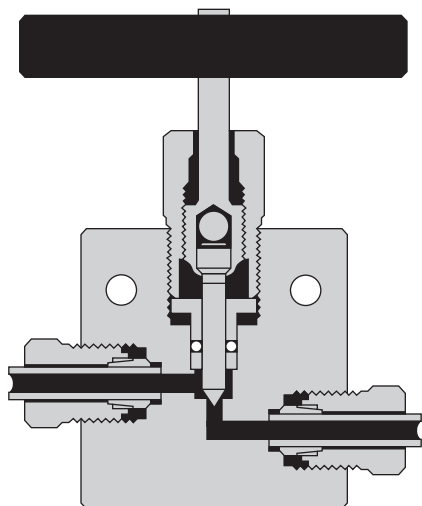

AF1 ($\frac{1}{16}$ ") and AF2 ($\frac{1}{8}$ ")
15,000 psi

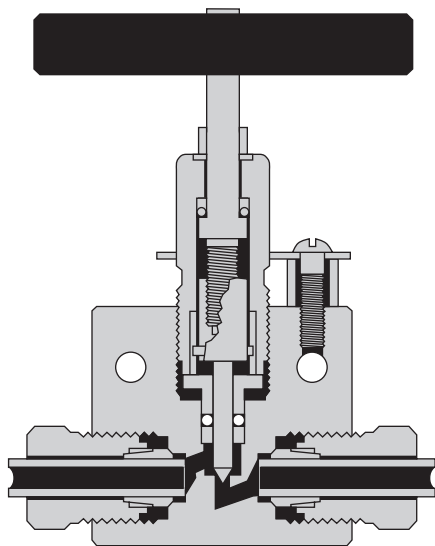

AF4 ($\frac{1}{4}$ ") and AF6 ($\frac{3}{8}$ ")
10,000 psi

Compression type tubing connections for $\frac{1}{16}$ " , $\frac{1}{8}$ " , $\frac{1}{4}$ " , and $\frac{3}{8}$ " O.D. tubing. Requires no special tooling for tubing preparation (simply cut off, deburr, and insert tubing into connection). Connection details are shown on page 2.A.

Non-rotating tip stems are standard for on-off service and insure long life on valve seats. Regulating tip stems are available at no additional cost, add - REG to the catalog number.

Glands and sleeves are supplied with each valve unless otherwise requested (glands and sleeves shown on 2.A).

Materials include high tensile type 316 stainless steel for the valve body and hardened 17-4PH stainless steel lower section stem.

Packing is Teflon (450°F) standard, with optional Viton (350°F), BUNA-N (200°F) or Grafoil (650°F) available at no additional cost.

Air operators for remote control operation are available for all valves. (Select required valve and add "HIPCO". Refer to section 7.0 for additional data).

Valve Features

- Non-rotating stem tips
- Packing below stem threads
- Type 316 ss high tensile bodies
- Positive gland lock device
- No stem adjustment needed
- Black T-handles or choice of 4 colors
- Tube sizes $\frac{1}{16}$ " through $\frac{3}{8}$ "

Taper Seal Valves

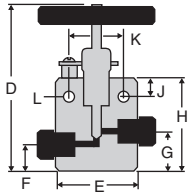

Two Way Straight Valves

| Tubing | Catalog No. | psi | Connection | Orifice | D | E | F | G | H | J | K | L | Thickness |
|------------|-------------|--------|------------|---------|--------|--------|--------|--------|----------|-------|--------|-------|-----------|
| 1/16" O.D. | 15-11AF1 | 15,000 | AF1 | 0.052" | 2 1/2" | 1 1/8" | 1/4" | 13/32" | 1 1/8" | 5/16" | 3/4" | 9/64" | 1/2" |
| 1/8" O.D. | 15-11AF2 | 15,000 | AF2 | 1/16" | 3 1/8" | 1 1/2" | 11/16" | 15/16" | 1 13/16" | 5/16" | 7/8" | 9/64" | 3/4" |
| 1/4" O.D. | 10-11AF4 | 10,000 | AF4 | 1/8" | 4 5/8" | 2" | 1/2" | 1 1/2" | 1 7/8" | 1/2" | 1 3/8" | 7/32" | 1" |
| 3/8" O.D. | 10-11AF6 | 10,000 | AF6 | 1/8" | 4 5/8" | 2" | 1/2" | 1 1/2" | 1 7/8" | 1/2" | 1 3/8" | 7/32" | 1" |

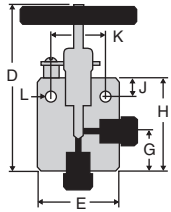

Two Way Angle Valves

| Tubing | Catalog No. | psi | Connection | Orifice | D | E | F | G | H | J | K | L | Thickness |
|------------|-------------|--------|------------|---------|---------|--------|---|---------|----------|-------|--------|-------|-----------|
| 1/16" O.D. | 15-12AF1 | 15,000 | AF1 | 0.052" | 2 3/8" | 1 1/8" | — | 2 1/32" | 1 3/8" | 5/16" | 3/4" | 9/64" | 1/2" |
| 1/8" O.D. | 15-12AF2 | 15,000 | AF2 | 1/16" | 3 1/8" | 1 1/2" | — | 15/16" | 1 13/16" | 5/16" | 7/8" | 9/64" | 3/4" |
| 1/4" O.D. | 10-12AF4 | 10,000 | AF4 | 1/8" | 5 3/16" | 2" | — | 1 1/16" | 2 7/16" | 1/2" | 1 3/8" | 7/32" | 1" |
| 3/8" O.D. | 10-12AF6 | 10,000 | AF6 | 1/8" | 5 3/16" | 2" | — | 1 1/16" | 2 7/16" | 1/2" | 1 3/8" | 7/32" | 1" |

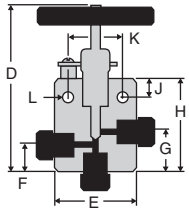

Three Way Valves / Two Pressure Connections

| Tubing | Catalog No. | psi | Connection | Orifice | D | E | F | G | H | J | K | L | Thickness |
|------------|-------------|--------|------------|---------|---------|--------|--------|---------|----------|-------|--------|-------|-----------|
| 1/16" O.D. | 15-13AF1 | 15,000 | AF1 | 0.052" | 2 3/4" | 1 1/8" | 1/2" | 2 1/32" | 1 3/8" | 5/16" | 3/4" | 9/64" | 1/2" |
| 1/8" O.D. | 15-13AF2 | 15,000 | AF2 | 1/16" | 3 1/8" | 1 1/2" | 11/16" | 15/16" | 1 13/16" | 5/16" | 7/8" | 9/64" | 3/4" |
| 1/4" O.D. | 10-13AF4 | 10,000 | AF4 | 1/8" | 5 3/16" | 2" | 1/2" | 1 1/16" | 2 7/16" | 1/2" | 1 3/8" | 7/32" | 1" |
| 3/8" O.D. | 10-13AF6 | 10,000 | AF6 | 1/8" | 5 3/16" | 2" | 1/2" | 1 1/16" | 2 7/16" | 1/2" | 1 3/8" | 7/32" | 1" |

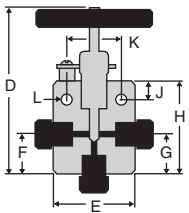

Three Way Valves / One Pressure Connection

| Tubing | Catalog No. | psi | Connection | Orifice | D | E | F | G | H | J | K | L | Thickness |
|------------|-------------|--------|------------|---------|---------|--------|---------|---------|----------|-------|--------|-------|-----------|
| 1/16" O.D. | 15-14AF1 | 15,000 | AF1 | 0.052" | 2 3/4" | 1 1/8" | 2 1/32" | 2 1/32" | 1 3/8" | 5/16" | 3/4" | 9/64" | 1/2" |
| 1/8" O.D. | 15-14AF2 | 15,000 | AF2 | 1/16" | 3 1/8" | 1 1/2" | 15/16" | 15/16" | 1 13/16" | 5/16" | 7/8" | 9/64" | 3/4" |
| 1/4" O.D. | 10-14AF4 | 10,000 | AF4 | 1/8" | 5 3/16" | 2" | 1 1/16" | 1 1/16" | 2 7/16" | 1/2" | 1 7/8" | 7/32" | 1" |
| 3/8" O.D. | 10-14AF6 | 10,000 | AF6 | 1/8" | 5 3/16" | 2" | 1 1/16" | 1 1/16" | 2 7/16" | 1/2" | 1 3/8" | 7/32" | 1" |

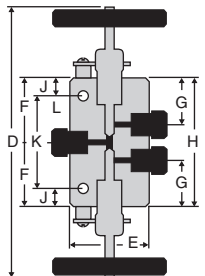

Three Way / Two Stem Connection Valves

| Tubing | Catalog No. | psi | Connection | Orifice | D | E | F | G | H | J | K | L | Thickness |
|------------|-------------|--------|------------|---------|--------|--------|----------|----------|--------|-------|--------|-------|-----------|
| 1/16" O.D. | 15-15AF1 | 15,000 | AF1 | 0.052" | 4 3/4" | 1 1/8" | 1" | 23/32" | 2" | 5/16" | 1 3/8" | 9/64" | 1/2" |
| 1/8" O.D. | 15-15AF2 | 15,000 | AF2 | 1/16" | 5" | 1 1/2" | 1 1/4" | 7/8" | 2 1/2" | 5/16" | 1 7/8" | 9/64" | 3/4" |
| 1/4" O.D. | 10-15AF4 | 10,000 | AF4 | 1/8" | 8 7/8" | 2" | 1 11/16" | 1 3/16" | 3 3/8" | 1/2" | 2 3/8" | 7/32" | 1" |
| 3/8" O.D. | 10-15AF6 | 10,000 | AF6 | 1/8" | 8 7/8" | 2" | 1 11/16" | 1 13/16" | 3 3/8" | 1/2" | 2 3/8" | 7/32" | 1" |



High Pressure Equipment

Glands/Sleeves/Plugs Elbows/Tees/Crosses

A complete range of elbows, tees, and crosses is available for all of the tubing connection sizes. Material is high tensile 316 stainless steel. Standard tubing glands and sleeves are furnished unless otherwise specified.

Connection Components

| Catalog No. | Tube Size | Gland | Catalog No. | Tube Size | Sleeve | Catalog No. | Tube Size | Plug |
|-------------|-----------|-------|-------------|-----------|--------|-------------|-----------|------|
| 15-2AM1 | 1/16" | | 15-2A1 | 1/16" | | 15-7AM1 | 1/16" | |
| 15-2AM2 | 1/8" | | 15-2A2 | 1/8" | | 15-7AM2 | 1/8" | |
| 10-2AM4 | 1/4" | | 10-2A4 | 1/4" | | 10-7AM4 | 1/4" | |
| 10-2AM6 | 3/8" | | 10-2A6 | 3/8" | | 10-7AM6 | 3/8" | |

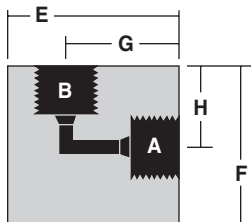

Taper Seal Elbows

| Catalog No. | Pressure Rating psi | Connections | A-B | E | F | G | H | Thickness |
|-------------|---------------------|-----------------|-----|--------|--------|-------|-------|-----------|
| 15-22AF1 | 15,000 | 1/16" O.D. TUBE | AF1 | 3/4" | 3/4" | 9/16" | 9/16" | 3/8" |
| 15-22AF2 | 15,000 | 1/8" O.D. TUBE | AF2 | 1 1/8" | 1 1/8" | 3/4" | 3/4" | 3/4" |
| 10-22AF4 | 10,000 | 1/4" O.D. TUBE | AF4 | 1 1/2" | 1 1/2" | 1" | 1" | 1" |
| 10-22AF6 | 10,000 | 3/8" O.D. TUBE | AF6 | 1 1/2" | 1 1/2" | 1" | 1" | 1" |

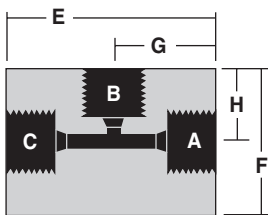

Taper Seal Tees

| Catalog No. | Pressure Rating psi | Connections | A-B-C | E | F | G | H | Thickness |
|-------------|---------------------|-----------------|-------|--------|--------|------|-------|-----------|
| 15-23AF1 | 15,000 | 1/16" O.D. TUBE | AF1 | 1" | 3/4" | 1/2" | 9/16" | 3/8" |
| 15-23AF2 | 15,000 | 1/8" O.D. TUBE | AF2 | 1 1/2" | 1 1/8" | 3/4" | 3/4" | 3/4" |
| 10-23AF4 | 10,000 | 1/4" O.D. TUBE | AF4 | 2" | 1 1/2" | 1" | 1" | 1" |
| 10-23AF6 | 10,000 | 3/8" O.D. TUBE | AF6 | 2" | 1 1/2" | 1" | 1" | 1" |

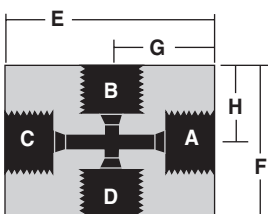

Taper Seal Crosses

| Catalog No. | Pressure Rating psi | Connections | A-B-C-D | E | F | G | H | Thickness |
|-------------|---------------------|-----------------|---------|--------|--------|------|------|-----------|
| 15-24AF1 | 15,000 | 1/16" O.D. TUBE | AF1 | 1" | 1" | 1/2" | 1/2" | 3/8" |
| 15-24AF2 | 15,000 | 1/8" O.D. TUBE | AF2 | 1 1/2" | 1 1/2" | 3/4" | 3/4" | 3/4" |
| 10-24AF4 | 10,000 | 1/4" O.D. TUBE | AF4 | 2" | 2" | 1" | 1" | 1" |
| 10-24AF6 | 10,000 | 3/8" O.D. TUBE | AF6 | 2" | 2" | 1" | 1" | 1" |

Line Filters

The line filters as shown utilize sintered stainless steel filter discs (AF2 & AF1 – 3 pc./set, AF4 & AF6 – 4 pc./set). Porosities are available as per the chart to the right. If not otherwise specified, 100 micron filter discs are supplied. (One micron = 0.001 millimeters). Material of bodies and end covers is high tensile 316 stainless steel. Standard tubing glands and sleeves are provided unless otherwise specified.

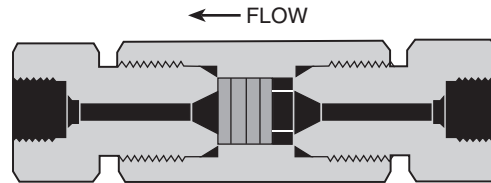

| Catalog No. | Pressure Rating psi | Connections | Length | Hex Size | Micron Size Filter Available | | | | | |
|-------------|---------------------|------------------|--------|----------|------------------------------|---|---|----|----|-----|
| | | | | | 0.5 | 2 | 5 | 10 | 40 | 100 |
| 15-51AF1 | 15,000 | 1/16" TAPER SEAL | 3 1/8" | 3/4" | ● | ● | ● | ● | ● | ● |
| 15-51AF2 | 15,000 | 1/8" TAPER SEAL | 3 1/8" | 3/4" | ● | ● | ● | ● | ● | ● |
| 10-51AF4 | 10,000 | 1/4" TAPER SEAL | 5 1/4" | 1 3/8" | ● | ● | ● | ● | ● | ● |
| 10-51AF6 | 10,000 | 3/8" TAPER SEAL | 5 1/4" | 1 3/8" | ● | ● | ● | ● | ● | ● |

Ball Check Valves

Ball type check valves insure flow in one direction only. Material for bodies, balls, and covers is high tensile 316 stainless steel. Standard tubing glands and sleeves are provided unless otherwise specified.

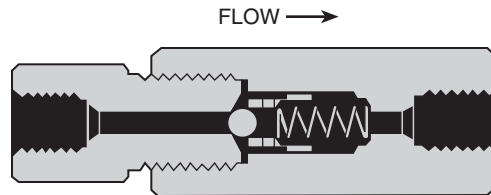

| Catalog No. | psi | Connections | Length | Hex |
|-------------|--------|------------------|---------|-----|
| 15-41AF1 | 15,000 | 1/16" TAPER SEAL | 3 1/8" | 1" |
| 15-41AF2 | 15,000 | 1/8" TAPER SEAL | 3 9/16" | 1" |
| 10-41AF4 | 10,000 | 1/4" TAPER SEAL | 3 7/8" | 1" |
| 10-41AF6 | 10,000 | 3/8" TAPER SEAL | 3 7/8" | 1" |

Soft Seat Check Valves

Soft seat check valves insure flow in one direction only and can be mounted in any position. These are highly reliable for both gas and liquid service. Standard O-ring (soft seat) material for the sealing surface is Buna-N (nitrile) with other materials including Teflon and Viton available on request. Temperature is limited by the choice of O-ring material. Material of all other parts is high tensile 316 stainless steel. Standard glands and sleeves are provided unless otherwise specified.

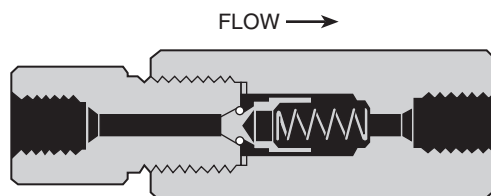

| Catalog No. | psi | Connections | Length | Hex |
|-------------|--------|------------------|--------|-----|
| 15-41AF1-T | 15,000 | 1/16" TAPER SEAL | 3 1/2" | 1" |
| 15-41AF2-T | 15,000 | 1/8" TAPER SEAL | 3 1/2" | 1" |
| 10-41AF4-T | 10,000 | 1/4" TAPER SEAL | 3 7/8" | 1" |
| 10-41AF6-T | 10,000 | 3/8" TAPER SEAL | 3 7/8" | 1" |



High Pressure Equipment

Safety Heads

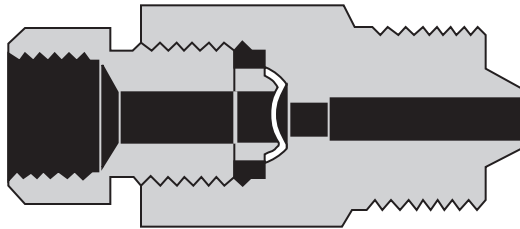

A choice of three safety head designs is available: male inlet, female inlet (straight), and tee type. The male inlet design can be inserted directly into the tubing connections of valves and various fittings such as tees and crosses, or located in pressure vessels.

Outlet connections on all sizes are $\frac{3}{8}$ " pipe (NPT). This outlet may be connected to a suitable discharge line to vent pressure to a safe location in the event of bursting of the rupture disc. Torque required for sealing rupture discs will range from 40 to 60 foot pounds, depending upon pressure and media being used.

Material of bodies and hold down nuts is high tensile 316 stainless steel. Hold down rings are hardened 17-4PH stainless steel. Standard tubing glands and collars (sleeves) are provided unless otherwise specified.

Note: Rupture discs are **not** included and must be ordered as a separate item.



Male Inlet Safety Heads

| Catalog No. | Pressure Rating psi | Inlet Connection | Length | Hex Size |
|-------------|---------------------|----------------------------|------------------|----------|
| 10-61AM4 | 10,000 | $\frac{1}{4}$ " TAPER SEAL | $2\frac{1}{8}$ " | 1" |
| 10-61AM6 | 10,000 | $\frac{3}{8}$ " TAPER SEAL | $2\frac{1}{8}$ " | 1" |

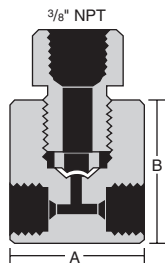

Tee Type Safety Heads

| Catalog No. | Pressure Rating psi | Inlet Connection | A | B | Thickness |
|-------------|---------------------|-----------------------------|----------------------|------------------|------------------|
| 15-63AF1 | 15,000 | $\frac{1}{16}$ " TAPER SEAL | $1\frac{1}{8}$ " HEX | $1\frac{3}{8}$ " | $1\frac{1}{8}$ " |
| 15-63AF2 | 15,000 | $\frac{1}{8}$ " TAPER SEAL | $1\frac{1}{2}$ " | $1\frac{1}{2}$ " | 1" |
| 10-63AF4 | 10,000 | $\frac{1}{4}$ " TAPER SEAL | 2" | $1\frac{3}{4}$ " | 1" |
| 10-63AF6 | 10,000 | $\frac{3}{8}$ " TAPER SEAL | 2" | $1\frac{3}{4}$ " | 1" |

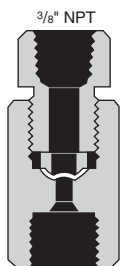

Female Inlet (Straight) Safety Heads

| Catalog No. | Pressure Rating psi | Inlet Connection | Length | Hex Size |
|-------------|---------------------|-----------------------------|------------------|----------|
| 15-61AF1 | 15,000 | $\frac{1}{16}$ " TAPER SEAL | $1\frac{7}{8}$ " | 1" |
| 15-61AF2 | 15,000 | $\frac{1}{8}$ " TAPER SEAL | $1\frac{7}{8}$ " | 1" |
| 10-61AF4 | 10,000 | $\frac{1}{4}$ " TAPER SEAL | $1\frac{7}{8}$ " | 1" |
| 10-61AF6 | 10,000 | $\frac{3}{8}$ " TAPER SEAL | $1\frac{7}{8}$ " | 1" |

Rupture Discs

1/4" Angled Seat

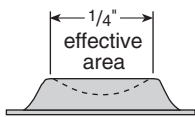

SPECIAL DISCS are available on special order for pressure ranges not shown above and in numerous materials and coatings. Consult factory for price and delivery.

Standard rupture discs are available from stock in burst pressures as listed in the chart below. Taper seal pressures are shaded. These discs are 316 stainless steel (except for 1000 psi which are inconel) and may be used with any of the safety heads shown. Note that these rupture discs are supplied with a tolerance of plus 6% and minus 3% of specified burst pressure. Samples of each batch are then tested and the actual average burst pressure is stamped on an accompanying metal tag. Factors influencing rupture disc life include corrosion, metal fatigue, and cyclic effects. Periodic replacement is recommended to prevent premature failure.

Standard Burst Pressures (in psi at 72°F)

| | | | | | | | | | |
|-------|-------|-------|-------|--------|--------|--------|--------|--------|--------|
| 1,000 | 3,000 | 5,000 | 7,000 | 9,000 | 11,000 | 17,500 | 25,000 | 37,500 | 55,000 |
| 1,500 | 3,500 | 5,500 | 7,500 | 9,500 | 11,500 | 18,000 | 27,000 | 40,000 | 60,000 |
| 2,000 | 4,000 | 6,000 | 8,000 | 10,000 | 12,500 | 20,000 | 30,000 | 45,000 | 65,000 |
| 2,500 | 4,500 | 6,500 | 8,500 | 10,500 | 15,000 | 22,500 | 35,000 | 50,000 | |

High Pressure Tubing

Tubing is cold drawn, seamless, and is supplied in the 1/8 hard condition (not annealed). Tensile strength is approximately 40 percent higher than that of annealed tubing. All tubing is manufactured in strict accordance with High Pressure Equipment Company specifications to insure tolerances and bore quality. Tubing is stocked in lengths of 18 to 22 feet but may be ordered in shorter lengths with **no additional cutting charge**.

Note: The 1/16" and 1/8" O.D. tubing sizes may be coiled for shipment. Larger sizes must be shipped in straight lengths.

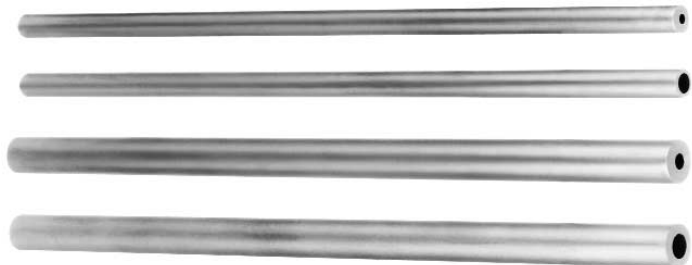

| | Tubing Size | Working Pressure psi | Type of Connection Used | Material | Catalog Order Number |
|-------|--------------------------|----------------------|-------------------------|----------|----------------------|
| 1/16" | 1/16" O.D. x 0.006" I.D. | 15,000 | 1/16" TAPER SEAL (AF1) | 316 SS | 15-9A1-006 |
| | 1/16" O.D. x 0.030" I.D. | | | | 15-9A1-030 |
| 1/8" | 1/8" O.D. x 0.060" I.D. | 15,000 | 1/8" TAPER SEAL (AF2) | 316 SS | 15-9A2 |
| 1/4" | 1/4" O.D. x 1/8" I.D. | 10,000 | 1/4" TAPER SEAL (AF4) | 316 SS | 10-9A4-316 |
| | | | | 304 SS | 10-9A4-304 |
| 3/8" | 3/8" O.D. x 1/4" I.D. | 10,000 | 3/8" TAPER SEAL (AF6) | 316 SS | 10-9A6-316 |
| | | | | 304 SS | 10-9A6-304 |



High Pressure Equipment

Taper Seal Connections

10,000 and 15,000 psi service

Taper Seal connections are available for $\frac{1}{16}$ ", $\frac{1}{8}$ ", $\frac{1}{4}$ ", and $\frac{3}{8}$ " O.D. tubing. No special tubing preparation is required – simply cut tubing to desired length, deburr and assemble.

The $\frac{1}{8}$ ", $\frac{1}{4}$ ", and $\frac{3}{8}$ " sizes utilize a two-piece sleeve which is supplied partially assembled. When the connection is assembled, the outer sleeve portion is permanently compressed over the inner portion to rigidly lock the sleeve onto the tubing. Note that the sleeve is not forced to bite into the tubing, but rather is clamped onto the tubing much like a machine collet.

Pressure ratings.

The $\frac{1}{16}$ " and $\frac{1}{8}$ " O.D. tubing size connections are rated to 15,000 psi working pressure.

The $\frac{1}{4}$ " and $\frac{3}{8}$ " O.D. sizes are rated to 10,000 psi working pressure.

Easy make-up connections.

One of the popular benefits of taper seal connections is that it is very easy to determine when the connection is "tight enough" during initial assembly. Simply rotate the tubing gland into the connection until you feel a "bottoming out" or "dead stop" of the wrench. This signals that the connection has been properly made.

A commercial thread lubricant is highly recommended to facilitate initial makeup of the connection, but such lubrication may be removed afterwards if desired. The Taper Seal connection can be disassembled and then reassembled an indefinite number of times.

Standard material for the gland is Type 316 stainless steel. The inner portion of the two-piece sleeve is Type 316 stainless steel. The non-wetted outer sleeve portion is zinc plated alloy steel. (Note that the $\frac{1}{16}$ " O.D. size is a one-piece sleeve design) in Type 316 stainless steel.

Tubing glands and sleeves are provided with all valves and fittings unless otherwise requested. (See chart at right for size details and catalog numbers).

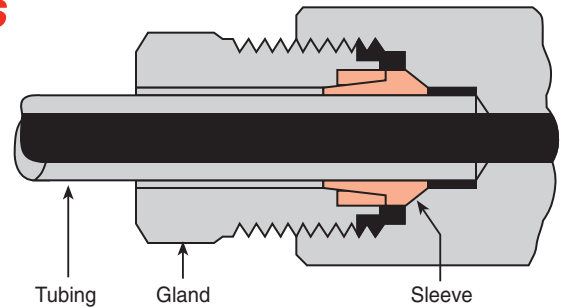

| | 15,000 psi | | 10,000 psi | |
|------------------------------|--|---------------------------------------|---------------------------------------|---------------------------------------|
| | AF1 <i>1/16" O.D. Tubing</i> | AF2 <i>1/8" O.D. Tubing</i> | AF4 <i>1/4" O.D. Tubing</i> | AF6 <i>3/8" O.D. Tubing</i> |
| Female Opening Detail | | | | |
| Gland | | | | |
| Sleeve | | | | |
| Plug | | | | |
| | 15-2AM1 | 15-2AM2 | 10-2AM4 | 10-2AM6 |
| | 15-2A1 | 15-2A2 | 10-2A4 | 10-2A6 |
| | 15-7AM1 | 15-7AM2 | 10-7AM4 | 10-7AM6 |